

# 30 and 40 Baler Ejector



JOHN DEERE

## TECHNICAL MANUAL 30 and 40 Baler Ejector

TM1311 (01JUN84) English

**John Deere Ottumwa Works**  
**TM1311 (01JUN84)**

LITHO IN U.S.A.  
ENGLISH



# 30 and 40 BALE EJECTORS Technical Manual TM-1311 (Aug-84)

## CONTENTS

### INTRODUCTION

#### SECTION 10—GENERAL

- Group 05—Specifications and Torque Values
- Group 10—Lubrication

#### SECTION 20—ELECTRICAL SYSTEM

- Group 05—Diagnosing Malfunctions
- Group 10—General Information and Wiring Diagrams
- Group 15—Console Control

#### SECTION 30—HYDRAULIC SYSTEM

- Group 05—General Information
- Group 10—Diagnosing Malfunctions
- Group 15—Hydraulic System Tests
- Group 20—Hydraulic Pump  
(Parker-Hannifin, 30 only)
- Group 25—Hydraulic Pump  
(Vickers, 40 only)
- Group 30—Hydraulic Pump  
(Cessna-No.24507, 30 only)
- Group 35—Hydraulic Pump  
(Cessna-No.25508, 30 and 40)
- Group 40—Control Valve
- Group 45—Throwing Cylinder
- Group 50—WYR-LOC Cylinder
- Group 55—Tilt Cylinder  
(Tie Rod, 30 only)
- Group 60—Latch Cylinder
- Group 65—Hydraulic Filter (40 only)

*All information, illustrations and specifications contained in this technical manual are based on the latest information available at the time of publication. The right is reserved to make changes at any time without notice.*

COPYRIGHT® 1984  
DEERE & COMPANY  
Moline, Illinois  
All rights reserved  
A JOHN DEERE ILLUSTRATION

0A9; E01;0000 A 221182

## INTRODUCTION

This technical manual is part of a twin concept of service:

### FOS Manuals—for reference

### Technical Manuals—for actual service

The two kinds of manuals work as a team to give you both the general background and technical details of shop service.

*Fundamentals of Service (FOS) Manuals* cover basic theory of operation, *fundamentals* of trouble shooting, *general* maintenance, and *basic* types of failures and their causes. FOS Manuals are for training new people and for reference by experienced technicians.

*Technical Manuals* are *concise* service guides for a *specific* machine. Technical Manuals are on-the-job guides containing only the vital information needed by an experienced technician.

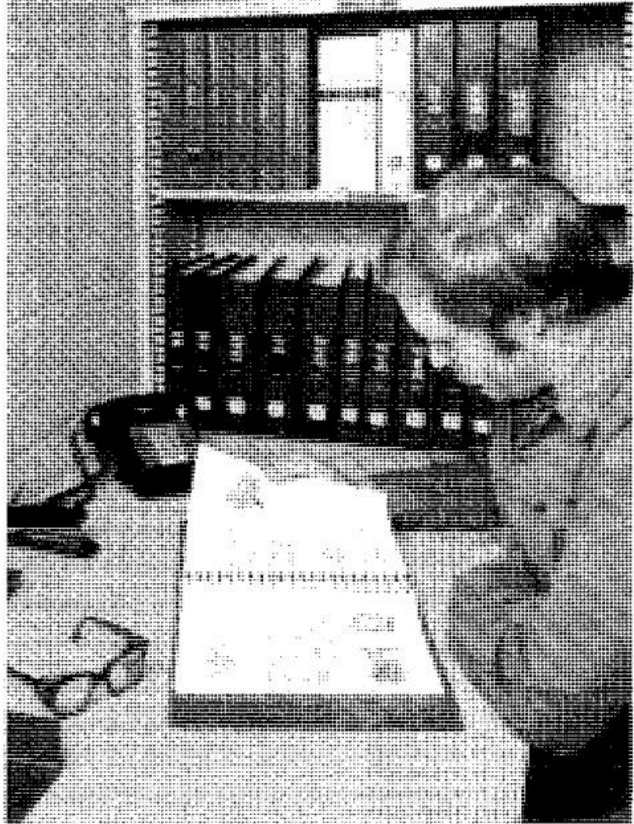

0A9;RW5559 E01;0000 G 112282

## FEATURES OF THIS TECHNICAL MANUAL

- John Deere ILLUSTRATION format emphasizing more detailed pictures and fewer words.
- Instructions and illustrations grouped together in easy-to-use modules.
- Removal and installation groups preceding some repair groups. These groups show how to remove and install components from the machine rather than from major components. They also show how to acquire access to major components of a machine.
- Exploded views showing parts relationship.

This technical manual was planned and written for you—an experienced technician. Keep it in a permanent binder in the shop where it is handy. Refer to it whenever in doubt about correct service procedures or specifications.

Using the technical manual as a guide will reduce error and costly delay. It will also assure you the best in finished service work.

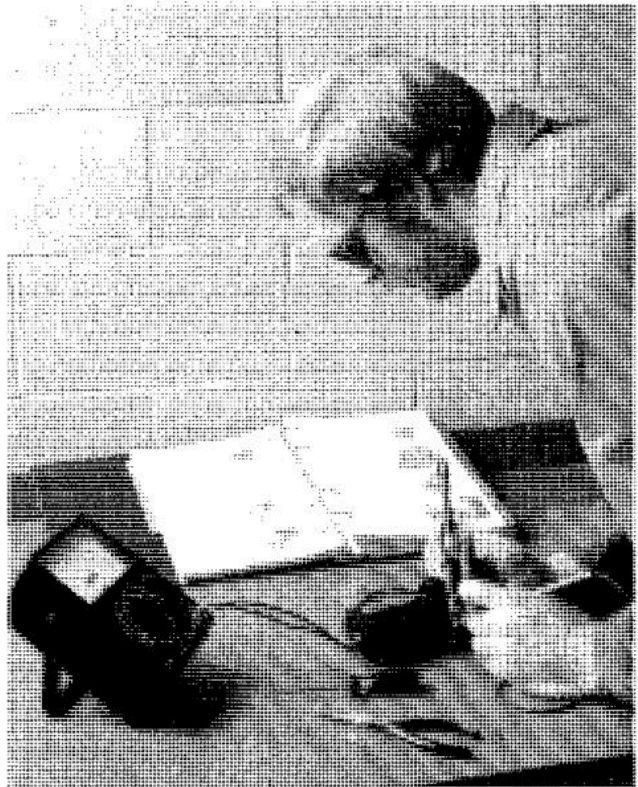

0A9;RW5560 E01;0000 H 190684

## SAFETY MESSAGES



This safety alert symbol and the word **CAUTION** identify important safety messages in this manual and on the machine. When you see this symbol, be alert to the possibility of personal injury and carefully read the message that follows.

0A9; E01;0000 E 190684

## NOTES

The word *NOTE* is followed by a statement that identifies a qualification or exception to a previous statement. A "NOTE" may also identify nice-to-know information pertinent to, but not directly related to the previous statement.

0A9; E01;0000 I 190684

## OBSERVE "IMPORTANT" MESSAGES

Messages labeled "Important" will appear in this manual and/or on the machine to provide specific instructions for performing adjustments, services, etc. If these instructions are not followed, it could result in damage to the machine.

0A9; E01;0000 J 190684

## USE A SAFETY CHAIN

A safety chain will help control drawn equipment should it accidentally separate from the drawbar while transporting. Using the appropriate adapter parts, attach the chain to the tractor drawbar support or other specified anchor location. Provide only enough slack in the chain to permit turning. See your John Deere dealer for a chain with a strength rating greater than the gross weight of the towed machine.

0A9; E01;;0000 B 200684

## FOLLOW SAFE PRACTICES

Do not attempt to pull bales from ejector while baler is operating.

Never attempt to unplug ejector unless lockout is engaged.

Always have side safety screens in place while operating.

Wear relatively tight and belted clothing to prevent being caught on some part of the machine.

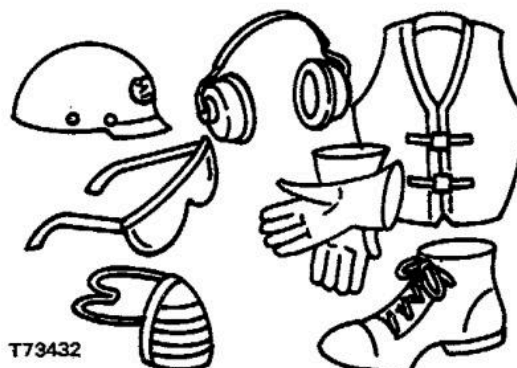

0A9;T73432 E01;;0000 C 200684

Always shut off tractor engine, disengage PTO and move lock-out lever (A) to lock position before attaching or detaching wagon.

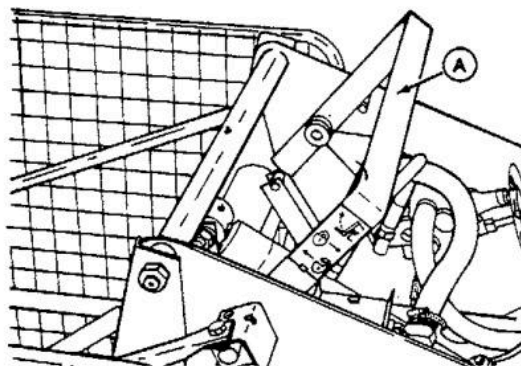

0A9;E24204 E01;;0000 D 200684

## AVOID HIGH PRESSURE FLUIDS

Escaping fluid under pressure can penetrate the skin causing serious injury. Relieve pressure before disconnecting hydraulic or other lines. Tighten all connections before applying pressure. Keep hands and body away from pinholes and nozzles which eject fluids under high pressure. Use a piece of cardboard or paper to search for leaks.

If ANY fluid is injected into the skin, it must be surgically removed within a few hours by a doctor familiar with this type injury or gangrene may result.



0A9;X9811 E01;;0000 K 200684

## PROTECT AGAINST NOISE

Prolonged exposure to loud noise can cause impairment or loss of hearing. Wear a suitable hearing protective device such as earmuffs (A) or earplugs (B) to protect against objectionable or uncomfortable loud noise.



0A9;E19364 E01;0000 L 200684

## DO NOT MODIFY MACHINE

Unauthorized modifications to the machine may impair the function and/or safety and affect machine life.

E01;0000 M 200684

## USE ADEQUATE SERVICE FACILITIES

Keep the service area clean and dry. Wet or oily floors are slippery. Wet spots can be dangerous when working with electrical equipment.

Make sure the service area is adequately vented.

Periodically check the shop exhaust system for leakage. Engine exhaust gas is dangerous.

Be sure electrical outlets and tools are properly grounded.

Use adequate light for the job at hand.

Service the machine on a level, hard-surfaced area.

Use lifting equipment and safety stands which have adequate strength for the job being performed.

E01;0000 F 201684

## GOOD ADVICE

Keep your machine damage-free and YOURS!

Follow the advice on these pages to reduce vandalism, discourage theft, and help recover your machine if it is stolen.

TAKE A BITE OUT OF  
**CRIME**

© 1979 The Advertising Council, Inc.



AB6;TS140 053;CRPRV A 181183

## RECORD IDENTIFICATION NUMBERS

1. Record Product Identification Number (PIN) of unit and identification numbers of engine, component, attachment, etc. EXACTLY as they appear on the plates.
2. Check that the complete and correct numbers appear on all documentation (insurance, financial, warranty, manufacturer's certificate of origin, etc.). Keep all documents in a safe location.
3. If available, participate in an "Owner Applied Numbering Program" and mark your own machines.



AB6;TS161 053;CRPRV B 091283

## MAINTAIN DOCUMENTED PROOF OF OWNERSHIP

1. Keep in a safe location all documents (invoices, warranty cards, manufacturer's certificate of origin, if available, etc.) that accompanied your machines at the time of purchase.
2. Take color photographs of each machine from several angles.
3. Maintain an up-to-date inventory of all machines. Check regularly to insure no machines have been stolen.

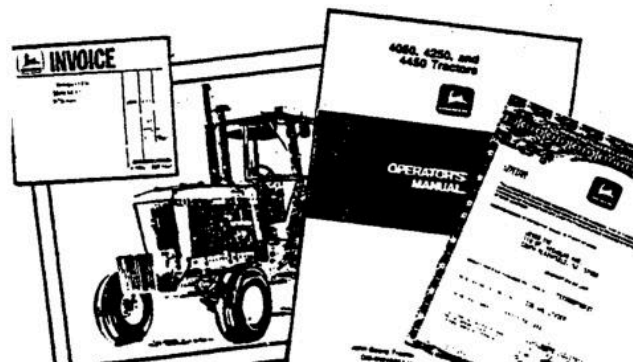

AB6;TS142 053;CRPRV C 181183

## PARK INDOORS OUT OF SIGHT

1. Lower all equipment making the machine harder to move.
2. Remove ignition key. If so equipped, lock cab doors, windows and any vandal protection devices. Place hard-to-move equipment in front of exits.
3. If machine is being stored, remove the battery or any essential component in the electrical system.
4. Set wheels in widest position making loading more difficult. Secure all openings to storage buildings.

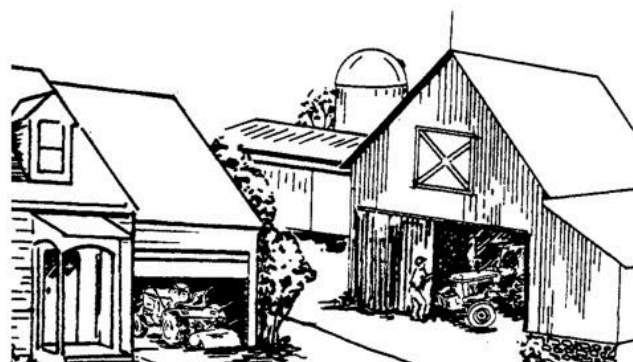

AB6;TS143 053;CRPRV D 100184

## PARKING OUTDOORS

1. Park machine in a fenced, well-lighted, locked area. Lower equipment, remove ignition key and lock cab doors, windows, and any vandal protection devices, if so equipped.
2. Make law enforcement aware of your presence in an area and provide them with a contact person to assist them in dealing with suspicious activity.
3. Solicit assistance from neighbors or merchants who permanently reside near the parking area.

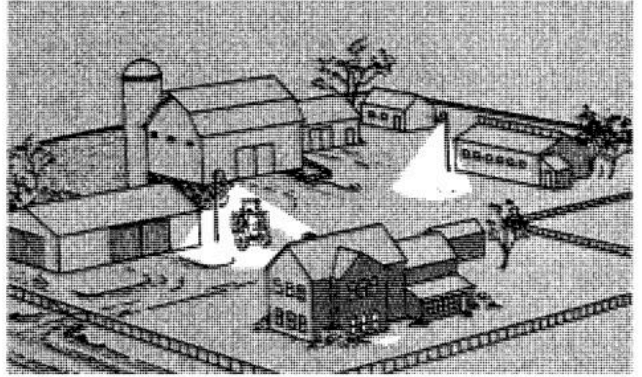

AB6;TS155 053;CRPRV E 091283

## REDUCE VANDALISM

1. Install vandal protection devices especially if parking machine in high-risk areas.
2. Solicit assistance for watching machine from individuals residing in the area.
3. Take written notes and report to law enforcement all suspicious vehicles or persons.
4. Participate in a "Neighborhood Watch Program."

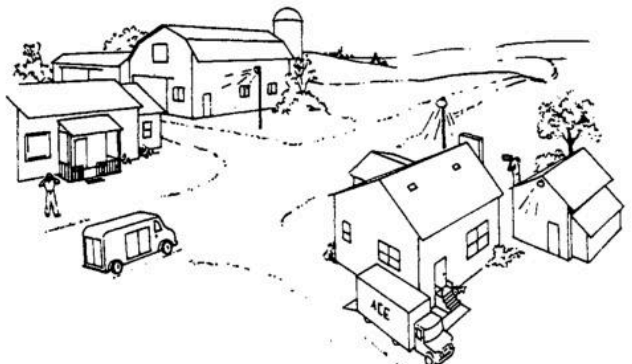

AB6;TS145 053;CRPRV F 100184

## REPORT THEFT

1. If a theft occurs, notify the law enforcement agency having jurisdiction and the insurance carrier immediately.
2. Give a full description and a complete identification number(s) to the investigating officer and insurance carrier.
3. If available, provide the investigating officer with photographs of the actual machine, manufacturer's literature and knowledge of any identifiable marks that would assist in identifying the machine.
4. Ask for verification that the stolen machine has been entered into the National Crime Information Center (NCIC) operated by the FBI in Washington D.C.
5. Notify your John Deere dealer of the theft and request that, if possible, a notice be posted that provides the description and identification information.
6. Regularly check the identification plates on all machines and report any removed plates to law enforcement immediately. Promptly contact your dealer and order a duplicate identification plate.



AB6;TS146 053;CRPRV G 181183



*Introduction*

# Section 10 GENERAL

## CONTENTS

### Page

#### GROUP 05—SPECIFICATIONS AND TORQUES

Specifications . . . . .	10-05-01
Torque Values . . . . .	10-05-02

#### GROUP 10—LUBRICATION

Lubricate Bale Ejector Properly . . . . .	10-10-01
Select Proper Grease . . . . .	10-10-01
Hydraulic Oils . . . . .	10-10-02
Use Approved Alternate Lubricants . . . . .	10-10-02
Store Lubricants Correctly . . . . .	10-10-02
Lubrication . . . . .	10-10-03
Control Valve . . . . .	10-10-03

*Contents*

**Group 05**  
**SPECIFICATIONS AND TORQUES**

**SPECIFICATIONS**

- Bale (Cross Section)** . . . . . 366 mm x 457 mm (14-in. x 18-in.)
- Length** . . . . . (Approximately) 686 mm to 965 mm (27-in. to 38-in.)
- Bale Weight** . . . . . (Varies with condition of hay) 36 kg (80 lbs) maximum
- Weight of Ejector (With wagon hitch, less oil):**
- (30) . . . . . (Approximately) 240 kg (530 lbs)
- (40) . . . . . (Approximately) 272 kg (600 lbs)
- Source of Power** . . . . . Hydraulic pump, belt driven from baler flywheel
- Hydraulic System Capacity:**
- (30) . . . . . 30.3 L (8 U.S. gal)
- (40) (Including filter). . . . . 32.2 L (8.5 U.S. gal)
- Hydraulic System.** . . . . . Open Center
- Baler.** . . . . . Works with John Deere 24, 224, 327, 336, 337, 346 and 347 Balers only
- Capacity** . . . . . Equal to Baler

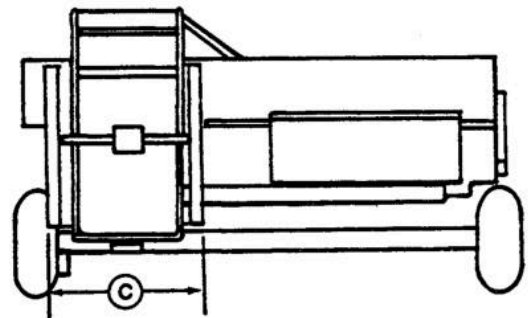
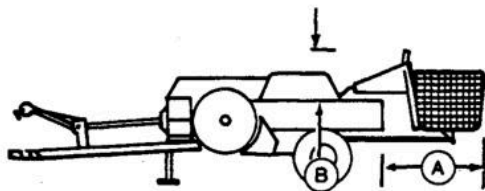

- A—Length (beyond end of bale case)** . . . . . (Approximately) 1 727 mm (68-in.)
- B—Height (above bale case top):**
- (30) . . . . . (Approximately) 686 mm (27-in.)
- (40) . . . . . (Approximately) 787 mm (31-in.)
- C—Width** . . . . . (Approximately) 1 211 mm (43-1/2-in.)

OA9;E24202 E24203 E01;;1005 L 200684

## TORQUE VALUES

Check all accessible bolts and nuts for proper tightness. If hardware seems loose, tighten it to the proper torque. The table below gives correct torque values for various bolts and cap screws.

Replace hardware with same strength bolt.

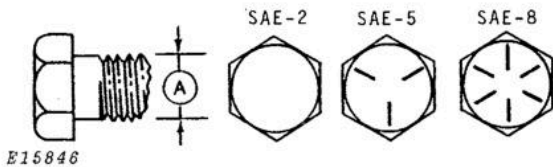

U.S. MEASUREMENT

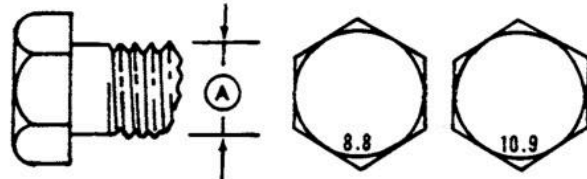

METRIC MEASUREMENT

Bolt Diameter "A"	Bolt Torque in N·m (Lb-Ft)		
	SAE 2	SAE 5	SAE 8
1/4"	Not Used	10 (14)	14 (19)
5/16"	Not Used	20 (27)	30 (41)
3/8"	31 (23)	47 (35)	68 (50)
7/16"	47 (35)	75 (55)	108 (80)
1/2"	75 (55)	115 (85)	163 (120)
9/16"	102 (75)	176 (130)	237 (175)
5/8"	142 (105)	231 (170)	325 (240)
3/4"	251 (185)	407 (300)	576 (425)
7/8"	217 (160)	603 (445)	929 (685)
1"	339 (250)	910 (670)	1 396 (1 030)
1-1/4"	450 (330)	1 235 (910)	1 979 (1 460)

Bolt Diameter "A"	Bolt Torque in N·m (Lb-Ft)	
	8.8	10.9
5 mm	6 (5)	9 (7)
6 mm	11 (9)	17 (13)
8 mm	28 (20)	40 (30)
10 mm	55 (40)	80 (59)
12 mm	95 (70)	140 (103)
16 mm	235 (173)	350 (258)
20 mm	475 (350)	675 (498)
24 mm	825 (608)	1 170 (863)
30 mm	1 630 (1 201)	2 320 (1 712)

**NOTE:** Bolts having lock nuts should be torqued to approximately 65% of amounts shown in above chart.

### LUBRICATE BALE EJECTOR PROPERLY

**CAUTION:** Before adjusting, cleaning or lubricating the machine:

1. Disengage all power.
2. Shut off tractor engine.
3. Move lock-out lever (A) to lock position.
4. Wait until baler flywheel has stopped rotating.

**CAUTION:** Do not clean, lubricate, or adjust your ejector while baler is running.

**IMPORTANT:** Correct selection and proper use of lubricating oils and grease is very important in keeping upkeep costs low, while providing long life with satisfactory service.

Use only lubricants specified in this section. Lubricate at the intervals listed and according to the following instruction.

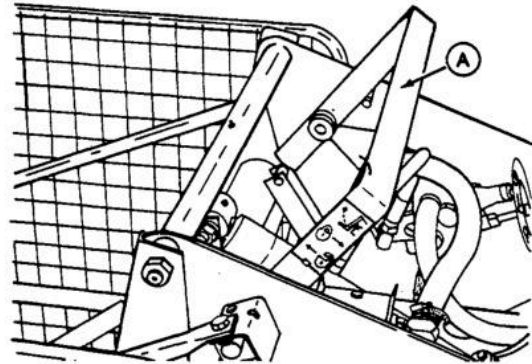

0A9;E24204 E01;;1010 M 200684

### SELECT PROPER GREASE

Depending upon the expected air temperature range during the service interval, use grease as shown on the adjoining temperature chart.

John Deere Multipurpose Grease is recommended. If other greases are used, use:

- SAE Multipurpose Grease
- SAE Multipurpose Grease containing 3 to 5 per cent molybdenum disulfide.

At temperatures below  $-30^{\circ}\text{C}$  ( $-22^{\circ}\text{F}$ ), use arctic greases such as those meeting military specification MIL-G-10924C.

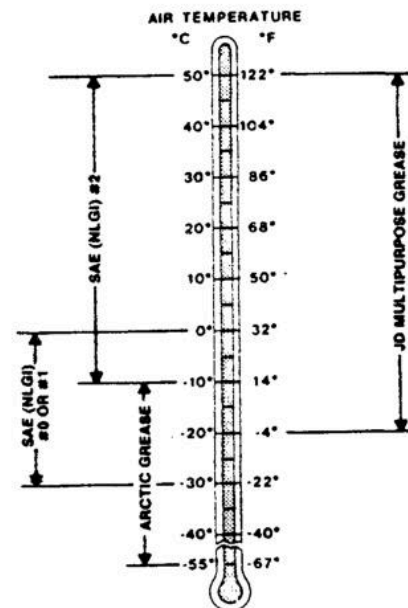

0A9;X9326 E01;;1010 N 200684

# John Deere 30 and 40 Baler Ejector Service Repair Manual PDF Download



Best John Deere 30 and 40 Baler Ejector

## John Deere 30 and 40 Baler Ejector Service Repair Manual PDF Download

This is the most complete Service Repair Manual for the John Deere 3020 Tractor Repair Service Manual ever compiled by mankind. This DOWNLOAD contains of high quality diagrams and instructions on how to service and repair your John Deere 30 and 40 Baler Ejector Repair from the front bumper rear. This is a must for the Do-It-Yourselfer! You will not be dissatisfied.

- General Maintenance
- Troubleshooting
- Engine Service / Repair
- Transmission Service / Repair
- Brake System
- Wiring Diagram
- Electrical System
- Suspension
- Periodic Lubrication
- Steering
- Cooling System
- Fuel Injection / Fuel System
- Emission System
- Heater/ Air Conditional
- Engine Control System
- Chassis / Body
- Restraint System
- Interior
- Differential / Drive Axle.

[John Deere 30 and 40 Baler Ejector Service Repair Manual](#)